



Studies on Developing the Manufacturing Process of Activated Carbon by Fluidized Gasification

メタデータ	言語: eng 出版者: 室蘭工業大学 公開日: 2014-07-14 キーワード (Ja): キーワード (En): 作成者: 柳井, 弘 メールアドレス: 所属:
URL	http://hdl.handle.net/10258/3523

Studies on Developing the Manufacturing Process of Activated Carbon by Fluidized Gasification

Hiroshi Yanai

Abstract

It has been engaged in developing the manufacturing process of activated carbon by fluidized gasification from various carbonaceous materials for the long period of 25 years or more. This work, coupled with laboratory research, has greatly advanced knowledge of the fluidized activation method and has resulted in the development of a series of commercial process that is usefully pretreated with Cl_2 gas after sifting or/and surface grinding procedure of cyclone dusts. This paper reviews briefly the nature of our process and operating results, while discussing the various problems that encounter in the course of development, and also describes our research in this field.

1 Introduction

Although a lot of work has been published on the mechanism of formation, manufacturing method, properties and applications of activated carbon, yet the operating conditions and equipment design affecting the yield and quality of activated carbon are trade secrets which are only available under licensing agreements⁵⁾¹²⁾.

In a case of preparing activated carbon from carbonaceous materials, especially for the purpose of deashing from these materials, pretreating those with Cl_2 gas has been known long since. And also the chemical pulp might be manufactured by treating woods with Cl_2 gas and removing lignin from them. These pretreating processes had come into operation with either a fixed bed or a moving bed. In the fluidized process, however, the atmosphere of Cl_2 gas was extremely diluted due to both fluidizing agents and generated gas, and then it was not possible to obtain the desired result sufficiently.

In the course of fluidized activation, since it is difficult to regulate the holding time of granules within the furnace and granules are activated from the surface during short times, both reactivity of materials and reaction temperature become essentially more important factors. Consequently there is a divergence of activity of cyclone dusts owing to the size distribution, and also the inside and the outside of granules⁴⁾⁹⁾.

For the purpose of a solution of these problems in the fluidized activation, it has been resulted in the development of a series of commercial process that is usefully pretreated with Cl_2 gas after sifting or/and surface grinding procedure over the wide range of carbonaceous materials. This paper reviews briefly the nature of our process and discusses the various problems that encounter in the course of development^{11)~14)}.

2 Fluidized gasification of brown coal and manufacture of activated carbon from cyclone dust¹⁰⁾

2-1 Relation between the gasification reaction and the activation of particles

Since 1957, the much cheaper activated carbon has been manufactured from the pulverized brown coal by the fluidized gasification³⁾⁶⁾⁷⁾¹⁰⁾. Up to the present, little reports along this line has been appeared¹⁾²⁾. On the basis of the operating results, this present paper is summerized the effects of operating conditions on the gasification and the activation. Various important factors concerned are discussed for the following items¹⁰⁾.

2-1-1 Crude material

Material used is such a non caking coal as brown coal produced near Kushiro areas, Hokkaido, being finer particles recovered in the concentration operation of coal. The size of particles is usually finer than 3 mm, being about 15% in water content. Materials are dried by the flash drier and the size range is arranged from 1.5 to 3.0 mm by sifting. Analysis of materials and dusts used in this experiment is shown in Table 1.

In this case, since it is difficult to make all of uniform size or to regulate holding time within the reaction chamber, it is necessary to select the material of better reactivity for the purpose of promoting the activation reaction throughly.

Table 1. Analysis of material used and of cyclone dust

Analytical item		Proximate analysis [%]					Calorific value [kcal/kg]	Ultimate analysis					
		Mois-ture	Ash	Volatile matter	Fixed carbon	Sulfur		Ash	Carbon	Hydro-gen	Oxygen		
Brown Feed (wet)	Coal Dust	5.42	10.46	45.03	39.09	0.23	6,537	11.00	68.55	5.87	13.01		
		3.89	44.58	3.66	47.87	0.30	4,217	46.38	51.85	1.04	0.10		
(dry base) [%]		Ash analysis [%]											
Nitro-gen	Sulfur	SiO ₂	Al ₂ O ₃	Fe ₂ O ₃	CaO	MgO	MnO	P ₂ O ₅	TiO ₂	SO ₃	K ₂ O	Na ₂ O	etc.
1.33	0.24	41.1	26.38	7.11	12.53	3.52	0.07	1.46	1.78	3.27	1.59	0.97	0.22
0.32	0.31	39.82	26.26	9.47	13.66	3.14	0.17	1.40	1.14	2.63	0.43	1.08	0.08

2-1-2 The reaction temperature and the holding time within a reactor

Both the reaction temperature and the holding time of granules within a reactor are important factors. On the basis of experimental results of charcoal in the fixed bed reactor, relations among the reaction temperature, the reaction time and the yield are described in the previous paper⁴⁾⁵⁾. Since in general the holding time of granules is the range from 5 to 25 min, as shown in Table 2,

being different owing to size of particles and operating conditions, it should be maintained the reaction temperature above 950°C and also at the same time it is preferable to arrange the narrow range of size as far as possible.

A particle size is gradually reduced, being activated with the progress of reaction. The granules of the size and apparent density corresponding to the flow rate at the outlet of reactor are expected to collect by the cyclone separator.

2-1-3 The average concentration of particles and the pressure drop within the reactor

The average concentration of particles and the pressure drop within a reactor are the important factors. The average concentration of particles is expressed as $C_d = V_d/V$,

where W_d , V_d : the weight and volume of holding particles within a reactor, V :

inner volume of reactor. The values of C_d are greatly effected on the gasification reaction and the activity of resulting dusts. In order to promote the reaction and to make uniform activity the value of C_d should be taken considerable small one. In a case of this brown coal, the activation is remarkably accelerated when $C_d < \text{ca. } 3\%$. In general, the pressure drop of fluidized furnaces is calculated from the expression, $\Delta P' = W_d/A$. The values of $\Delta P/\Delta P'$ are much more than unity, as shown in Table 2. The operating results of three fluidized furnaces with different diameters and the same type as shown in Fig. 1 are summarized in Table 2.

2-1-4 The feed rate and the quantity of steam

It becomes clear that the feed rate is extremely a important factor. Dusts are sifted into three groups (x , y and z) corresponding to sifting yield S_x , S_y and S_z . The activity is expressed as

Table 2. Characters of three fluidized-gasification furnaces with different diameters

No. of furnace	P_{300}	P_{500}	P_{750}	
Scale of furnace {	A	0.071	0.196	0.442
	V	0.233	0.833	2.443
Feed rate [kg/hr]	35~50	55~120	100~270	
Air-coal ratio [-]	2.3~2.5	1.9~2.5	2.2~2.0	
Steam-coal ratio [-]	0.2~0.3	0.2~0.4	0.24~0.5	
W_d	3~4	7.5~10	5~13	
V_d	10~13	23~31	16~41	
$C_d = V_d/V$	4~5.5	2.8~3.7	0.7~1.7	
Pressure drop {	ΔP	40~80	50~70	16~40
	$\Delta P'$	42~56	38~51	11~30
	$\Delta P/\Delta P'$	1.46	1.42	1.43
t_h	15~20	13~18	6~15	
C_{av}	35	51	63.5	
Capacity {	[kg/m ² /hr]	510~700	280~620	250~610
	[kg/m ³ /hr]	160~215	70~150	45~110

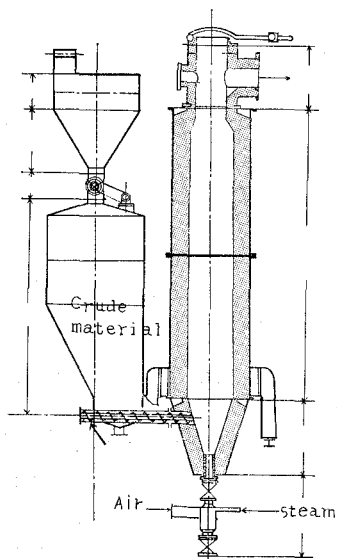

Fig. 1. Fluidized activation furnace internally heated

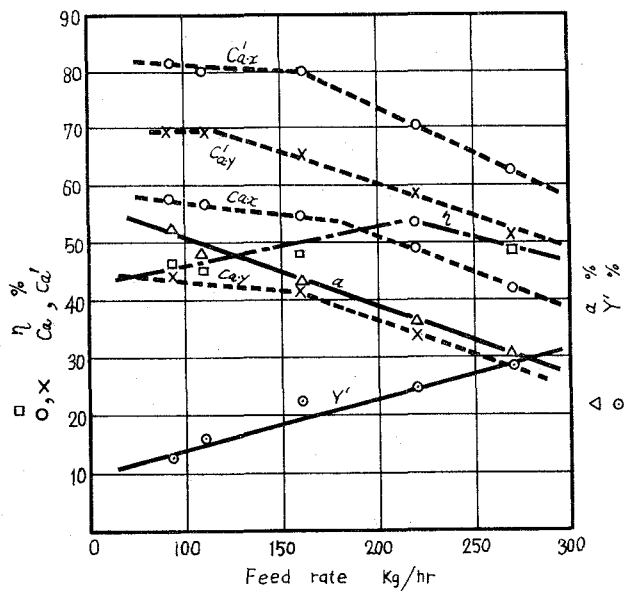

Fig. 2. Effect of feed rate on activation and gasification in P_{750} furnace

caramel decolorizing power (C_a) and the efficiency (cold) η is expressed as the ratio of acquired heat of generated gas to the calorific value of wet coal kg. Effects of the feed rate on the activation and the gasification reaction in the P_{750} furnace are given in Fig. 2 and 3. It may be concluded from these results as follows.

1) There are the optimum feed rates according to the scale of furnaces. The optimum conditions for the gasification and for the activation are approximately the same.

2) The yield of cyclone dust and the average size of particles are directly proportional to the feed rate, on the contrary, the activity and the ash content are reversely proportional to the feed rate.

3) Sx and $Sx+Sy$, in either cases, are approximately proportional to the feed rate, however Sy is reversely proportional to the feed rate.

Provided that the reaction temperature is thoroughly high, the increase of steam is in favour of the activation until the steam coal ratio becomes about 0.5. As a general rule, however, the introduction of excessive steam resulted in the increase of the remaining steam and consequently the heat efficiency is dropped.

The same materials as described above are gasified in a certain Winkler

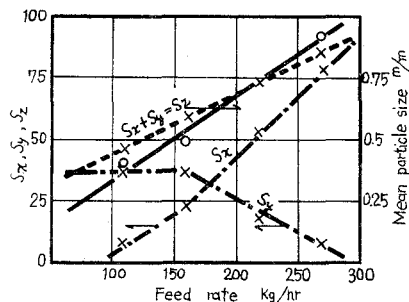

Fig. 3. Effect of feed rate on activation and gasification in P_{750} furnace

generator and the degree of activity are measured for several samples. All these ones, however, are not of practical use. In these practices, since the operating conditions are regulated to manufacture a producer gas as a main product, it has been found that the feed rate is too much to promote the activation reaction compared with the scale of furnace. The results of these experiments lend some supports to these above conclusions.

2-2 Properties of cyclone dust

2-2-1 The distribution in the nature of dust

Cyclone dusts prepared in the continuous operation are sampled at random. The relations between the size distribution and the ash content, the activity of dusts are given in Fig. 4. This distribution in the nature are unavoidable owing to the change of operating condition. In general, in proportion to the reduction of particle size, the ash content increases and the activity decreases gradually and there is a break point near the size of 42 mesh. Judging from these experimental results, it may be possible to develop a process that is separated the

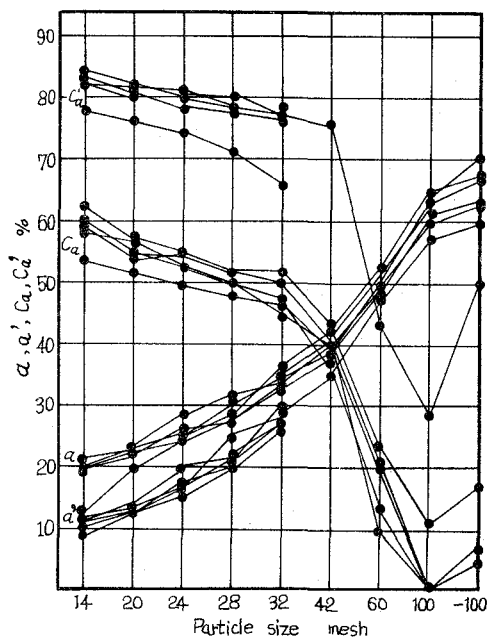

Fig. 4. Change in ash content and activity due to particle size of dust

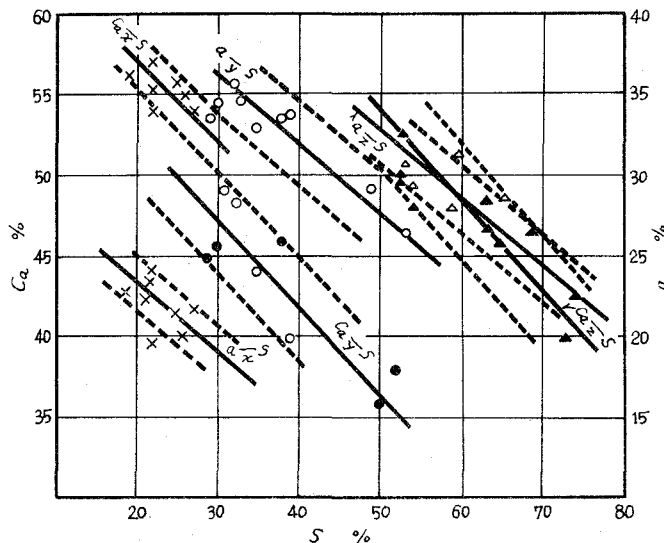

Fig. 5. Relations among ash content, sifting yield and activity of cyclone dust

more activated carbon with the less ash content by sifting alone as described latter.

2-2-2 Relation among the ash content, the sifting yield and the activity of cyclone dusts

In the commercial practice for a long time, keeping the operating condition within the allowable limits, several samples are sifted into three groups (x , y and z) corresponding to the sifting yield, S_x , S_y and S_z , as already mentioned and the ash content and the decolorizing power Ca are estimated respectively. Linear relations between Ca and S , Ca and a (%) within each group are observed as shown in Fig. 5 and 6. In other words, the ash content and the activity are reversely proportional to the sifting yield. Furthermore the activity is directly proportional to the ash content. In turn these relationships may not always be observed among different groups. And it is difficult to observe these relationships for the powder finer than 42 mesh because of the thermal and mechanical pulverization and the change of operating condition.

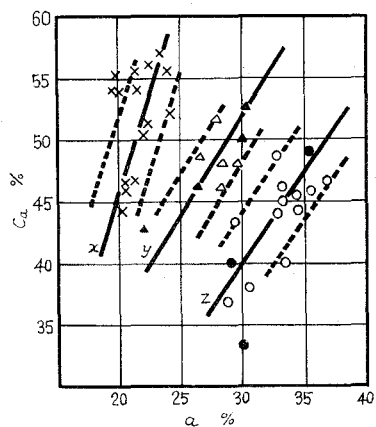

Fig. 6. Relations between ash content and activity of cyclone dust

2-3 Preparation of the activated carbon by means of the separation and the purification

For resulting particles the activity is found to be highest on the surface and lowest at the core. This phenomenon is extremely observed in a case of carbonized materials such as wood charcoal, especially coarse particles.

2-3-1 Experimental procedure¹²⁾

Several experimental apparatus are developed for trial. For example, the horizontal rotary drum made of wire gauzes, containing dust particles and porcelain balls, is rotated. In another example dust particles, containing within the vessel, are mechanically agitated as shown in Fig. 9 and rubbed off a surface part. In addition to the above test, a porcelain ball mill (180 mm ϕ \times 180 mm), containing 100 g of dust particles and several porcelain balls (25 mm ϕ \times 20), is rotated at 60 rpm, being sifted by the Tyler screen at given intervals.

2-3-2 Experimental result

Cyclone dusts illustrated in Fig. 4 are sifted by wire screen of 42 mesh and surface grinding test are carried out for particles retained on 42 mesh screen. Changing the ratio of powder to core, the ash content and the activity are estimated for each of these, as given in Table 3. For example, provided that the ratio of powder to core is 1.5, the powder and the core are 58.3% and 35% in caramel decolorizing power respectively. The larger the ratio of powder to core,

Table 3. Manufacture of the higher active carbon from activated parts ground away from the surface of particles

G [%]		Before washing with HCl sol.			After washing with HCl sol.		
		C_a [%]	a [%]	filterability	$C_{a'}$ [%]	a' [%]	pH
60	Powder	58.3	28.0	49.4	82.2	15.4	3.6
	Core	35.0	30.6	50.8	—	—	—
70	Powder	53.3	28.5	50.4	79.5	17.2	3.6
	Core	33.6	33.7	51.4	—	—	—
80	Powder	48.8	28.2	50.5	75.5	18.7	3.5
	Core	26.6	36.6	50.8	—	—	—

the lower will be the decolorizing power of either products. The surface grinding operation, coupled with the sifting operation mentioned before, has resulted in the development of a series of commercial plant separating only the higher activated part.

2-4 The mechanism of the activation and the application

When organic carbonaceous materials, being either semicarbonized or uncarbonized, are gasified at the fluidized furnace, it has been recognized that in general the adsorptive behaviour of activated carbon prepared from resulting dusts are similar to the activated carbon by $ZnCl_2$, as given in Table 4.

Table 4. Characters of several active carbons prepared from dusts made from different materials

Name of active carbons	Materials	Method of activation	Properties						
			Moisture [%]	Ash [%]	pH	M.B. [cc]	C_a [%]	KMnO ₄ [mg/g]	Bulk density
A	lignite	steam (fluidized)	4.0	8.5	6.7	7.0	90.5	85	0.200 ~0.230
B	"	"	4.7	8.1	7.2	4.0	65.0	50	0.350 ~0.400
C	brown coal	"	5.0	25.2	10.2	3.0	40.0	—	0.450
D	"	"	5.0	14.0	3.7	5.0	81.0	—	0.300
E	charcoal	"	5.3	0.5	6.0	15.0	92.6	185	—
F	pulp waste	—	6.0	3.1	6.5	10.0	90.0	—	—
G	saw dust	$ZnCl_2$	35.0	6.5	5.9	7.0	93.5	147	—

Stated in another way, in this case the carbonization and the activation of brown coal may be occurred at the same time. The volatile matter and inherent water are suddenly evaporated as a gaseous state at the higher temperature during the initial stage and the steam and gases are penetrated into resulting pores during the subsequent stage. Being purified the resulting carbon surface, the porous structure should be highly developed. Consequently resulting pores during the

initial stage are macro one. These pores contribute very little to the surface area but serve as avenues of entrance to the interior. Micropores, being characteristic of activating carbonized materials, are developed in and around these macropores during the subsequent stage. Clearer views as to the nature of this mechanism may emerge from the results of further work which is in progress¹⁵.

The present writer carried out various practical tests for the activated carbon prepared from lignite by means of the same process before this. Visual observation also showed that these carbons are extraordinary in sugar refining and moreover are remarkable for decolorizing and deodorizing of animal and vegetable oils as already illustrated⁸. Furthermore in order to desulfur an industrial carbon dioxide and to purify the waste gas from factory, a process that the resulting granular carbons, corresponding to the part of core explained in 2-3-2, may be possible to serve in the fluidized state has been developed¹².

Judging from the economic prospect and particular properties as described above, these activated carbons will be favourable to pretreating of dark colored solutions, the decolorization and the deodorization of raw fatty oils (especially fish oil), water and air purification, and also will be possible to practice over the wide range of industrial applications.

3 Fluidized activation of carbonaceous materials by pretreatment with Cl_2 gas¹¹

3-1 The pretreating apparatus and fluidized activation furnace

The industrial plant used in Cl_2 gas pretreatment consists of several units in parallel and each unit is the moving bed reactor, being about 4 m in height and 6 m in diameter. In practice, asbestos slate pipes are connected with short lead pipe and slightly bent lead pipe is also used at the outlet as shown in Fig. 7. Cl_2 gas is introduced axially into the lower end of the vertical retort at the constant rate from the pressured reservoir. The capacity of each unit is possible to regulate the range between 100 and 400 kg/hr, the contact time being about 10 minutes. This treatment is carried out at room temperature at the start, however, sometimes it reaches to near 60°C owing to the exothermic reaction. Crude granules are charged by screw conveyer at the upper end, feed

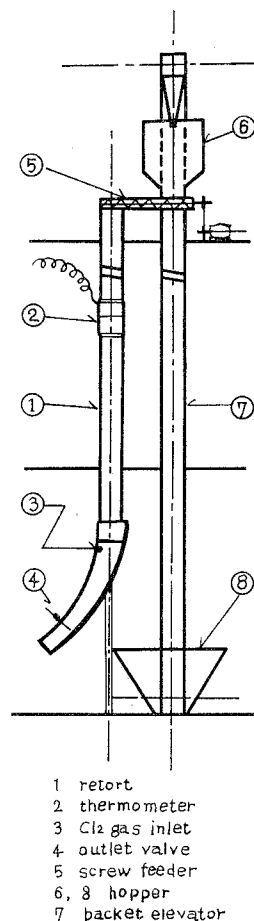

1 retort
2 thermometer
3 Cl_2 gas inlet
4 outlet valve
5 screw feeder
6, 8 hopper
7 bucket elevator

Fig. 7.
Pretreating apparatus
(Cl_2 gas)

rate being regulated by a continuous transmission. They are intimately contacted with Cl_2 gas countercurrently. In order to prevent the leakage of Cl_2 gas from the top and also to maintain the Cl_2 gas content of materials nearly uniform, both the feed rate and discharge rate of materials are controlled continuously.

In a case of carbonized materials, since the primary activated carbons are pretreated with Cl_2 gas by taking advantage of their adsorbability there are little troublesome due to the generation of heat and the leakage. The consumption of Cl_2 gas is the range between 2 and 4 per cent per unit weight of the primary carbon.

In a case of pretreating such uncarbonized materials as woody lignite, sawdust and residual lignin, of course, the presence of water should be necessary. However, since the water of materials are evaporated due to the generating heat and is condensed at the top of retort, materials should be preliminarily dried to the water content range of 10 to 20%. The range of Cl_2 gas consumption used is 0.6 to 1.2% per weight of feed materials.

The fluidized activation unit consists of the refractory vertical reactor with a oil combustion chamber, as shown in Fig. 8, being about 5 m in height and 1.2 m in inside diameter. Since the results of operation have been already reported⁽¹¹⁾⁽¹²⁾⁽¹⁴⁾, only the characteristics of this unit are summarized as follows:

a) This furnace is possible to feed the finer granules and to maintain these granules for longer time within the reacting chamber. Consequently the difference of activity between the inside and the outside of granules may be minimized. And also in spite of an internal heating system, the combustion loss of materials may be minimized. It is thus possible to prevent the increase of ash content and to increase the yield of products.

b) The waste heat is highly utilized and also the finer dust of products is thoroughly recovered.

3-2 The two stage gaseous activation of carbonized materials

In general, the commercial charcoals consists of chars with wide variation in their properties owing to their sources and the different carbonized condition. Hence there is the difference among the degree of activation, keeping activation conditions as constant as possible. In the primary fluidized activation, these charcoals are gasified slightly and reduced the difference among these chars as

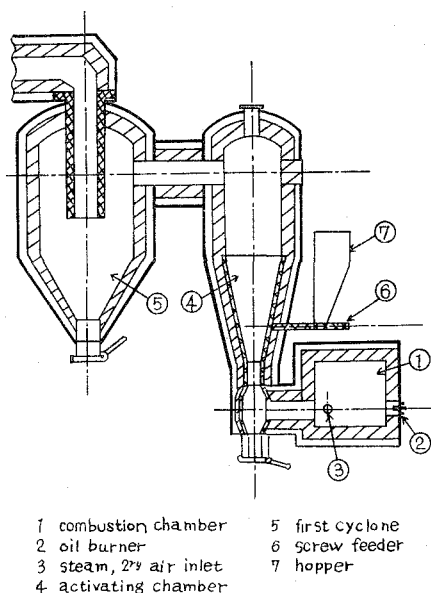

Fig. 8. Fluidized gasification furnace with a combustion chamber

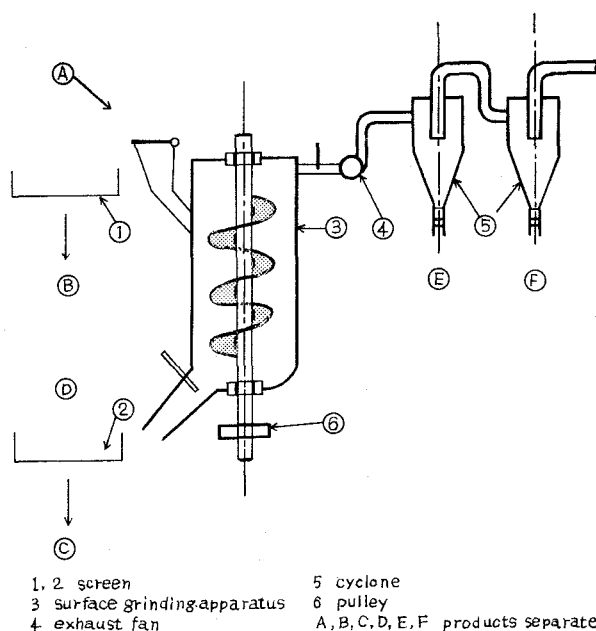

Fig. 9. Flow sheet of sifting- and surface grinding-process

much as possible. The primary activated carbon may be transferred to the second stage with or without sifting according to the content of dirty products. According to the nature and the size of particles, especially in a case of coarse particles, the primary activated carbon should be rubbed off the surface part by the surface grinding apparatus and separated the grinding powder by sifting apparatus, as shown in Fig 9. The core is transferred to the second stage.

By the introduction of these operations, scattering and excessive gasifying loss are minimized and the yield of products are increased, the property and the yield of products separated by sifting and surface grinding operation are given in Table 5 as a typical example.

In the second stage the primary activated carbons are pretreated to the desired degree with Cl_2 gas or chemical reagents that are generated Cl_2 gas by thermal decomposition at higher temperature. The adsorbed quantity of Cl_2 gas is evaluated from a weight increase. The more activated part is possible to adsorb Cl_2 gas more and more than the less activated part. Thus in the course of the secondary activation, the latter is gasified more and more, in contrast to this, the former is controlled the gasification reaction by the aid of an adsorbed Cl_2 gas. The adsorbed Cl_2 gas penetrates directly into granules at the highest concentration. Thus the activation is accelerated and carbon granules are purified since the ash is partly converted into chloride and removed by sublimation. The range of feeding particle size is extended to use the finer powder of 80 mesh or less, because of developing these processes. Consequently the yield increases strikingly.

Table 5. Property and yield of products (P_1) separated by sifting- and surface grinding-process

Separated product (P_1) (cf. Fig. 8)	Yield for cyclone dust [%]			Property Ca (M.B.)		
	(1)	(2)	(3)	(1)	(2)	(3)
A	86.8	77.3	57.5	80	84.2	75.7
B	13.2	22.7	42.5	80	86.0	74.0
C	32.0	22.5	25.0	87 (14)	92.1 (16)	85.6 (13)
D	47.0	45.0	15.0	59.1	66.1	43.3
E + F	7.8	9.8	17.5	90.4 (16)	95.1 (19)	88.4 (15)

note (1), (2): 3~4 mesh particles charged
(3): 4~15 mesh particles charged

These processes are possible to practice continuously within a set of this furnace. Since a cyclone separator is maintained at the temperature above 850°C, the Cl_2 gas may be introduced from a side wall of bottom into the dust collected in separator.

3-3 The gaseous activation of organic carbonaceous materials

Among the lignites, especially woody lignites are less ash content and are more activatable than coaly lignites. Therefore it is attempted to concentrate those by mechanical procedures such as drying, pressing, crushing and sifting. Let the range be divided into two class intervals, 4 to 15 and 15 to 50 mesh, corresponding to the average ash content 2.1 and 4.1% respectively. These granules are dried by the flash drier to the extent of the water content between 10 and 20% and are pretreated with Cl_2 gas or other chemical reagents as mentioned above¹³.

In practice, the operating conditions used in this process vary from 920 to 1000°C in activation temperature, 130 to 180 kg/hr in feed rate, 30 to 45 l/hr in heavy oil consumption, 2 to 3 in air to lignite ratio and 0.25 to 0.3 in steam to lignite ratio. The pressure difference between the oil combustion chamber and the top of the reaction chamber is ordinarily taken to be the range of 20 to 40 mm in water column and the operating pressure at the outlet of the first cyclone is regulated to be zero. The waste heat is used not only drying and semicarbonizing of materials, preheating of air and steam, heat to boiler, but also sometimes a part of waste gas is recirculated into the combustion chamber together with an additional steam and air. Residual lignin (wood sugar) is also pretreated with Cl_2 gas, being dried to the degree of water content 13%. Thus it is gasified under the same reaction conditions as woody lignite.

3-4 Effects of pretreating with Cl_2 gas

Effects of pretreating with Cl_2 gas on the property and the yield of resulting products would be highly desirable, as given in Table 6. The development of

Table 6. Effects of Cl₂ gas on the activation of charcoal

Particle size used [mesh]	Pretreat	Yield for raw material [%]	Property before washing				
			pH	M. B.	Ca	Cl'	a
2~30	—	13.5	9.4	15.5	86.0	—	3.2
2~30	Cl ₂	14.4	7.4	15.0	93.5	0.06	1.5
2~80	Cl ₂	16.9	8.0	14.5	91.5	0.04	2.1

the activation method composed of the 2 stages resulted in an uniformity of the degree of activity, using relatively small amount of Cl₂ gas. From the results of the surface grinding test by a ball mill, significant effects were noticed on either the uniform activity, the purity or the ash content of products.

In a case of such organic carbonaceous materials as woody lignite and residual lignin, the effects of Cl₂ gas on the activation are compared with or without the pretreatment of Cl₂ gas while maintaining other variables constant. The results are shown in Table 7, where purified products (*P*₂) are purified crude products *P*₁ by washing with dil HCl and then hot water.

Table 7. Effects of Cl₂ gas on the activation of organic carbonaceous materials

Material used	Pretreat	Product	Yield for charge [%]	Property					
				pH	M. B.	Ca	Cl'	Sm	a
Lignite (woody)	Cl ₂	<i>P</i> ₁	14.0	10.3	7.5	80	0.11	0.43	6.5
		<i>P</i> ₂	—	6.5	6.5	93	0.03	0.24	4.7
	—	<i>P</i> ₁	14.3	11.0	7.5	71	—	0.70	8.0
		<i>P</i> ₂	—	6.7	7.0	88	—	0.42	5.5
Residual lignin (wood sugar)	Cl ₂	<i>P</i> ₁	16.0	10.5	7.0	68.4	0.13	0.65	—
		<i>P</i> ₂	—	6.5	7.0	84.3	0.03	0.25	—
	—	<i>P</i> ₁	12.0	11.0	7.5	70.0	—	0.80	—
		<i>P</i> ₂	—	6.7	6.5	85.0	—	0.50	—

Table 8. Property of active carbons prepared by these processes

Active carbon (<i>P</i> ₂)	Material used	Sugar sol. test	
		<i>S</i> _a	pH of sugar sol.
1	charcoal	62.3	5.72
2	lignite (woody)	54.0	5.46
Darco S-51	—	52.3	5.75
Darco G-60	—	54.6	5.05

Note Sugar sol.: conc. 50 Brix pH 7.0 stammer color value 51

These data are shown more effective improvement in the properties, e.g. water soluble matter, ash content, pH and decolorizing power, etc. Some decolorizing properties of carbons prepared by these processes are given in Table 8 in comparison with the other processes.

4. Conclusion

In the fluidized gasification process for the preparation of active carbons from organic carbonaceous materials and their carbonized products, the effective procedure of pretreating their granular particles with Cl_2 gas in a vertical tube after sifting or/and surface grinding operation, was introduced. The results indicated that both the yield and the quality of cyclone dusts were improved, from which it has been able to obtain uniformity in their activity at a minimum loss of Cl_2 gas.

From the operation data on fluidized gasification furnaces, in which pulverized brown coal was gasified by using steam and air as fluidizing agents, the effects of operating condition on the gasification and activation were derived.

1) There are the optimum feed rates according to the scale of furnaces. The optimum conditions for the gasification and for the activation are approximately the same. The activation is remarkably accelerated when $C_a < \text{ca. } 3\%$.

Based on the analytical data on cyclone dusts produced in continuous operations, their characteristics were discussed.

2) When dusts are sifted into three groups (x , y and z), usually certain relations are observed to exist among the ash contents, the activities and the sifting yields of these groups.

3) In proportion to the reduction of particle size, the ash content increases and the activity decreases gradually. In each particle, the activity is found to be highest on the surface and lowest at the core, so that it is possible to prepare higher active carbon by collecting more activated parts ground away from the surface of these particles.

The effects of pretreatment with Cl_2 gas on the activation were also described.

4) For carbonized materials like charcoal, the primary activated products, with or without sifting and surface grinding procedure, are treated with Cl_2 gas according to their adsorptive ability, and then the secondary activation is followed.

5) For such organic carbonaceous materials as lignite and the residual lignin in wood sugar manufacturing, etc., lignin is chlorinated in the presence of 10-20% moisture. Thus the reactivity is increased and the activating reaction is promoted.

(Received May 10, 1971)

Nomenclature

A	: sectional area of fluidized furnace	(m ²)
a	: ash content of dust or/and before washing with HCl sol.	(weight %)
a'	: ash content of dust after washing with HCl sol.	(weight %)
Ca	: caramel decolorizing index or/and before washing HCl sol.	(%)
Ca'	: caramel decolorizing index after washing with HCl sol.	(%)
C_a	: average concentration of particle	(%)
G	: grinding yield	(weight %)
MB	: methylene blue test	(cc)
$\Delta P, \Delta P'$: pressure drop (observed, calculated)	(kg/m ²)
$P_{300}, P_{500}, P_{750}$: fluidized gasification furnace of retort dia. 300, 500, 750 mm ϕ	
P_1, P_2	: Product before and after washing with HCl sol.	(-)
S	: sifting yield (Tyler's standard screen)	(%)
S_d	: decolorizing index for sugar sol.	(%)
S_m	: water soluble matter in product	(%)
t_h	: average holding time of particles	(min)
V	: volume of fluidized gasification furnace	(m ³)
V_a	: volume of fluidized particles	(m ³ or l)
W_a	: weight of fluidized particles	(kg)
Y, Y'	: yield of cyclone dust (observed, calculated)	(weight %)
η	: efficiency (cold)	(%)

Subscripts

x	: particle retained on 24 mesh screen
y	: particle retained between 24 and 42 mesh screen
z	: (= $x+y$) particle retained on 42 mesh screen

Literature cited

- 1) Batchelder, H. R., Sternberg, J.C.: I. E. C., **42**, 877 (1950).
- 2) Batchelder, H. R., Busche, R. M.: I. E. C. **45**, 1856 (1953).
- 3) Hayashi, G.: Fuel Soc. (Japan), **38**, 588 (1959).
- 4) Iwasaki, T., Yanai, H.: Chem. Eng. (Japan), **18**, 81 (1954).
- 5) Iwasaki, T., Yanai, H.: Japan Patent No. 178584 (Apr. 1950).
- 6) Terui, A.: Chem. Eng. (Japan), **23**, 318 (1959).
- 7) Terui, A.: Fuel soc. (Japan), **38**, 598 (1959).
- 8) Tochigi kasei Co. Ltd.: Yushi, **7**, 47 (1954).
- 9) Yanai, H.: Fuel Soc. (Japan), lecture (Aug. 1954).
- 10) Yanai, H.: Chem. Eng. (Japan), **26**, 518 (1962).
- 11) Yanai, H.: Chem. Eng. (Japan), **26**, 1089 (1962).
- 12) Yanai, H.: "Industrial Research Institute, Hokkaido" Report, (Aug. 1961).
- 13) Yanai, H.: Fuel Soc. (Japan), **41**, 976 (1962).
- 14) Yanai, H.: Wood Industry **23**, 162 (1968).
- 15) Yanai, H.: J. Chem. Soc. (Japan), **71**, 960 (1968).